

Operating Instructions
Read and observe these operating instructions!

Vacuum Controller with Control Unit

VC 900

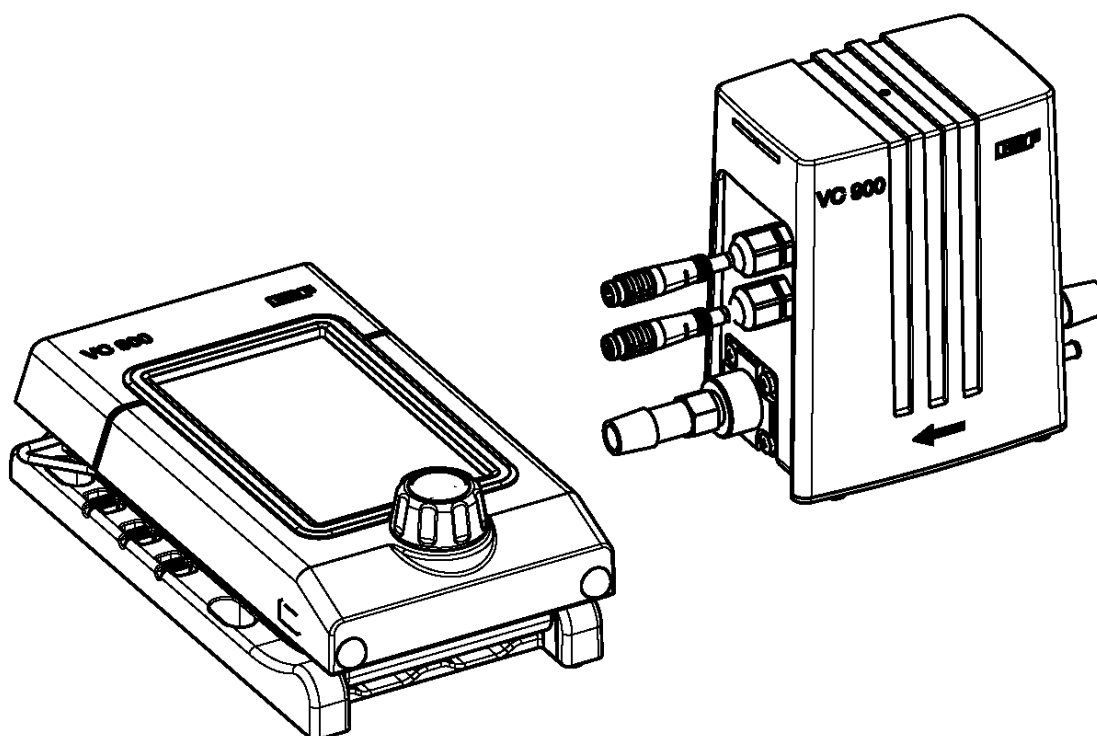

KNF Neuberger GmbH
Alter Weg 3
79112 Freiburg
Germany
Tel. +49 (0)7664 / 5909-0
Fax +49 (0)7664 / 5909-99
E-Mail: info@knf.de
www.knf.de

Items included in delivery:

- Vacuum controller
- Control unit
- Power supply for vacuum controller
- USB cable for connecting vacuum controller to PC
- Operating instructions
- CD with digital operating instructions and software for operating the vacuum controller with a PC

Contents	Page
1. About this document	4
1.1. Use of the Operating Instructions	4
1.2. Symbols and markings	4
2. Use	5
2.1. Intended use	5
2.2. Improper use	6
3. Safety	7
4. Technical data	8
4.1. General	8
4.2. Vacuum controller	9
4.3. Control unit	10
4.4. Software	11
5. Components and functions	12
5.1. Assembly	12
5.2. Functions	13
6. Setup and connection	14
6.1. Set up or install	14
6.2. Connections	16
7. Operation	17
7.1. Initial start-up	17
7.2. Stopping operation	18
8. Operating the vacuum controller	19
8.1. Vacuum controller	19
8.1.1. General functions and displays	19
8.1.2. Operation	20
8.2. Software	24
9. Troubleshooting	25
10. Spare parts and accessories	28
10.1. Spare parts	28
10.2. Accessories	28
11. Returns	29
12. Health and safety clearance and decontamination form	30

1. About this document

1.1. Use of the Operating Instructions

The Operating Instructions are part of the vacuum controller VC 900.

- ➔ Carefully study the Operating Instructions before using the VC 900.
- ➔ Always keep the Operating Instructions handy in the work area.
- ➔ Forward the Operating Instructions to any subsequent owners of the vacuum controller.

Project controller

Customer-specific project controllers (vacuum controllers prefixed with "PJ" or "PM") may differ from the Operating Instructions.

- ➔ In the case of project controllers, take note of any additionally agreed specifications.

i Compliance with the operating instructions is essential for safe and reliable operation of the VC 900. Failure to do so may result in damage or injury.

1.2. Symbols and markings

Warning



WARNING

This symbol indicates a danger statement.

It also indicates the possible consequences of failure to observe the warning. The signal word (i.e. "Warning") indicates the level of danger.

- ➔ Here you will see actions for avoiding the danger and potential consequences.

Danger levels

Signal word	Meaning	Consequences if not observed
DANGER	warns of immediate danger	Consequences include death or serious injuries and/or serious property damage.
WARNING	warns of potential danger	Death or serious injuries and/or serious property damage are possible.
CAUTION	warns of a potentially dangerous situation	Minor injuries or damage to property are possible.

Tab. 1

Other information and symbols

- ➔ This indicates an activity (step) that must be carried out.
- 1. This indicates the first step of an activity to be carried out. Any additional steps are consecutively numbered.
- i** This symbol indicates important information.

2. Use

2.1. Intended use

The VC 900 is designed for measuring and controlling vacuum applications.

It is designed exclusively to measure and control gases and vapors.

Make sure that the installation location is dry and that the system is protected against water in the form of rain, spray, splashes and drips.

The VC 900 is solely for use in indoor areas.

Owner's responsibility

Operating parameters and conditions

Only install and operate the VC 900 under the operating parameters and conditions described in Chapter 4, Technical data.

Protect the VC 900 against humidity.

Requirements for media to be controlled

Before using a medium, check the compatibility of the materials of the VC 900, valves, seals and hoses with the medium.

Before controlling a medium, check whether the medium can be controlled safely.

Only control gases that remain stable under the pressures and temperatures occurring in the VC 900.

Accessories

Laboratory equipment and additional components connected to the VC 900 must be designed for the pneumatic specifications of the VC 900 (see Chapter 4, page 8).

2.2. Improper use

The VC 900 must not be operated in an explosive atmosphere.

The VC 900 is not suitable for controlling dusts.

The VC 900 is not suitable for controlling liquids.

The VC 900 must not be used if the entry of air or gas into the VC 900 during venting (ventilation valve) or an open gas ballast valve could result in the creation of reactive, explosive or otherwise hazardous mixtures (e.g. with the medium).

Never apply positive pressure to the suction side of the VC 900.

3. Safety

The VC 900 is built according to the generally recognized rules of technology and in accordance with the pertinent occupational safety and accident prevention regulations. Nevertheless, potential dangers during use can result in injuries to the user or others or in damage to the pump systems or other property.

Only use the VC 900 when it is in a good technical and proper working order, in accordance with its intended use, observing the safety advice within the Operating Instructions, at all times.

Personnel	<p>Make sure that only trained and instructed personnel or specially trained personnel work on the VC 900. This especially applies to assembly, connection and servicing work.</p> <p>Make sure that all personnel have read and understood the Operating Instructions, especially the "Safety" chapter.</p>
Working in a safety-conscious manner	Observe the accident prevention and safety regulations when performing any work on the VC 900 and during operation
Handling dangerous media	When working with dangerous media, observe the safety regulations for handling such media.
Handling flammable media	Be aware that the VC 900 is not designed to be explosion-proof.
Ventilating the VC 900	When ventilating the VC 900 with air or inert gas, be sure to prevent formation of reactive or explosive media. The maximum permissible operating pressure at the ventilation connection (Fig. 1/14, p. 12) is 0.1 bar g.
Environmental protection	All replacement parts should be properly stored and disposed of in accordance with the applicable environmental protection regulations. Ensure adherence to the pertinent national and international regulations. This especially applies to parts contaminated with toxic substances.
Standards	<p>The VC 900 conforms to the Directive 2011/65/EU (RoHS2).</p> <p>The VC 900 conforms to the safety regulations of the EC Directive 2014/30/EU concerning Electromagnetic Compatibility and the EC Directive 2014/35/EU relating to electrical equipment designed for use within certain voltage limits. The requirements of the following harmonised standards have been used:</p> <ul style="list-style-type: none"> ▪ DIN EN 61326-1 – Class A ▪ DIN EN 61010-1 ▪ DIN EN 50581 <p>The VC 900 corresponds to IEC 664:</p> <ul style="list-style-type: none"> ▪ the overvoltage category II ▪ the pollution degree 2
Customer service and repairs	<p>All repairs to the VC 900 must be carried out by the relevant KNF Customer Service team.</p> <p>Housings with voltage-carrying parts may be opened by technical personnel only.</p> <p>Use only the original KNF power supply that was delivered.</p>

4. Technical data

4.1. General

<i>Ambient and media temperature</i>	
Permissible media and ambient temperature	+10°C to +40°C
<i>Pneumatic performance</i>	
Max. permissible operating pressure [bar g]	0
Max. permissible pressure at inert gas connection [bar g]	0.1
<i>Electrical data</i>	
Nominal voltage* [V]	100-240 +/-10%
Frequency [Hz]	50/60
Operating voltage [V DC]	24
Power supply	Via supplied power supply unit, cable length approx. 1.50 m, with adapter set: EURO / UK / USA / AUS
Max. operating current [A]	1.0
Max. power consumption [W]: - Standby - vacuum valve, ventilation valve and cooling valve switched on	2.5 5.0
Protection class	IP30
<i>Other parameters</i>	
Maximum permissible ambient relative humidity (not condensing)	80% for temperatures up to 31°C, decreasing linearly to 50% at 40°C
Maximum altitude of installation [m above sea level]	2000

Tab. 2

*automatic mains power adjustment

i Use only the original KNF power supply unit to supply power to the VC 900.

4.2. Vacuum controller

<i>Electrical connections</i>	
Power supply connection (DC charging socket)	 External diameter: 6.3 mm Inside diameter: 2 mm
Pressure sensor connection	3-pole round connector
Ventilation valve/vacuum valve connection	4-pole round connector
<i>Electrical data</i>	
Display	Illuminated LCD graphic display
Pressure display (selectable)	mbar, bar, hPa or Torr
Measurement range	0-1.1 bar abs.
Measuring accuracy (at 25°C)	$\leq \pm 0.2\%$ FS
Resolution [mbar]	1
Maximum control range [mbar abs.]	1013 - 2
Interface	Mini USB
<i>Other parameters</i>	
Dimensions W x H x D [mm]	181 x 101 x 67*
Cut-out for front installation** L x W [mm]	154 x 70
Weight [kg]	0.5***

Tab. 3

* condition on delivery

** drilling pattern see Fig. 3

*** without power supply

4.3. Control unit

<i>Materials for parts contacting the medium</i>	
Adapter control unit	PPS
Non-return valve	FFPM
Flange G1/8"	Stainless steel 1.4571
Hose connector gas inlet	PVDF
Hose connector gas outlet	PVDF
Hose connector inert gas connection	Brass, nickel-plated
Pressure transducer	Ceramic / 1.4404
Ventilation valve:	
Anchor seal	FFPM
O-ring	FPM
Tube	1.4301
Vacuum valve	FFPM
<i>Pneumatic connections</i>	
Hose connector gas inlet	For hose ID10
Hose connector gas outlet	For hose ID10
Hose connector inert gas connection	For hose ID4
<i>Other parameters</i>	
Dimensions: W x H x D [mm]	155 x 109 x 60
Weight [kg]	0.7

Tab. 4

4.4. Software

The USB connection between the PC and VC 900 is operated as an RS232 interface. Accordingly, in the operating system it is managed as an additional COM connection and can be addressed with conventional terminal software. Please see the delivered CD for information on operating the vacuum controller via software.

5. Assembly and functions

5.1. Assembly

- 1 Touchscreen
- 2 Snap-in positions for wire support
- 3 I/O switch
- 4 Rotary/push knob for:
 - adjusting pump speed and setpoint pressure
 - switching to manual operation
- 5 Wire support
- 6 Mounting options for foot
- 7 USB port for connecting vacuum controller to PC
- 8 Foot
- 9 Connection socket for pressure sensor
- 10 Connection socket for KNF vacuum pump
- 11 Connection sockets for valves
- 12 Power supply connection
- 13 Vacuum chamber connection
- 14 Connection for ventilation/inert gas
- 15 Connection to vacuum source
- 16 Connection cable, valves to vacuum controller
- 17 Connection cable, pressure sensor to vacuum controller

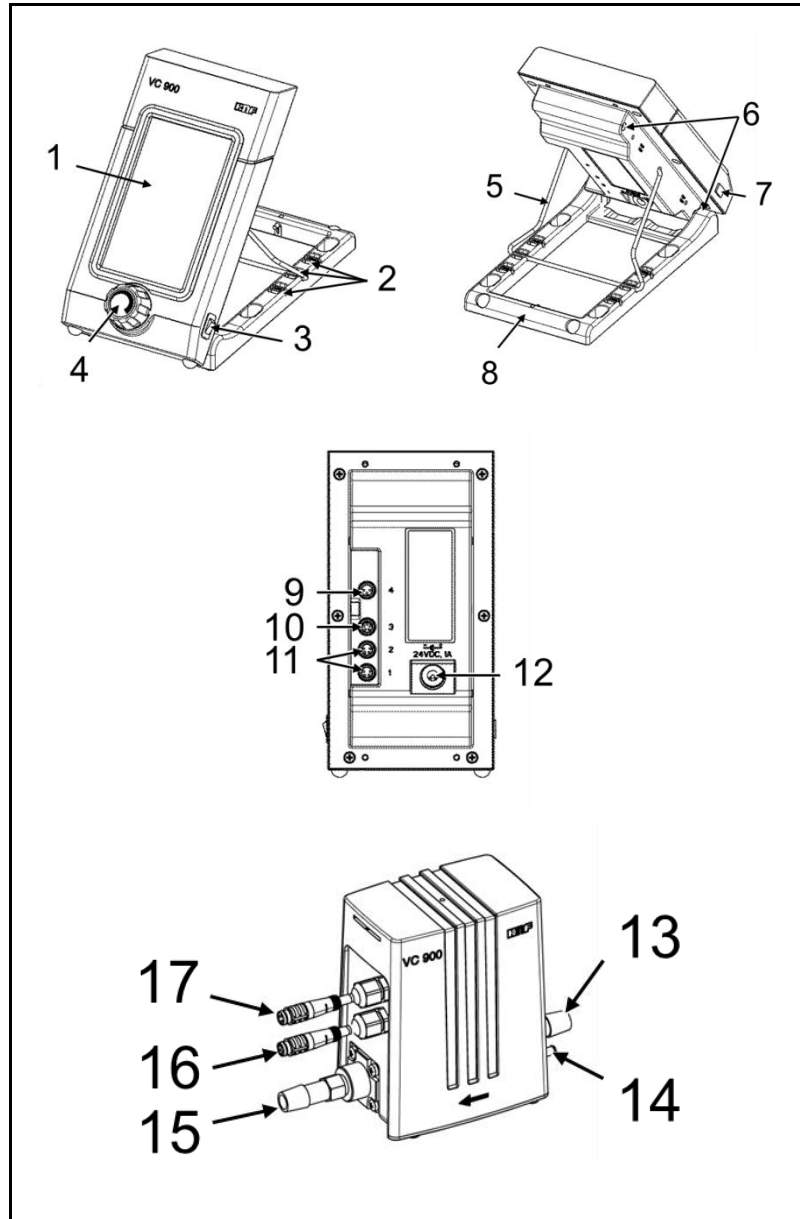

Fig. 1: Vacuum Controller VC 900

You can operate the vacuum controller either via the touch display and the rotary/push knob (Fig. 1/1 and 4, p. 12) or via a PC. Use the mini USB interface for PC operation (7).

The control unit contains a pressure sensor, a vacuum valve, and a ventilation valve and is activated via the vacuum controller.

The vacuum chamber (13), the vacuum source (15), and, if required, inert gas for ventilation (14) are connected to the control unit.

The control unit is connected electrically with the vacuum controller via the 3-pole (pressure sensor) and the 4-pole (vacuum valve, ventilation valve) connection cable (16 and 17).

5.2. Functions

The vacuum controller can be operated in four different modes:

- **Evacuate**
A vacuum chamber is evacuated as quickly as possible by means of the vacuum source that is connected to the control unit.
- **i** If a variable KNF pump is connected to the vacuum controller, the vacuum chamber can be evacuated with variable pump capacity.
- **Pressure Control**
The vacuum controller controls the system pressure to the selected value (constant pressure).
- **Automatic (only if a variable KNF pump is connected to the vacuum controller)**
The vacuum controller automatically finds the vapor pressure of the sample and adjusts the process pressure accordingly.
- **Function**
The vacuum controller controls pressure according to the entered pressure curve. Up to 10 different pressure curves can be stored. The following process parameters can be entered:
 - Setpoint pressure at various times after starting the process
 - Coolant valve (accessory) ON and OFF with point in time after start of process

At any time during an active process, you can switch to **manual process control**. Functions for evacuation and pressure control are available simultaneously. When activating manual process control, the current actual pressure will be adopted as the first setpoint pressure. In other words, process pressure will be initially "frozen" at the current value.

For smart process control, the modes of operation **can be combined as you wish**. For example, after boiling point detection in automatic mode, the following modes of operation can be used to specifically distill the solvent off:

- **Evacuate**
(constant rate of evaporation for optimum utilization of the condenser)
- **Function**
(operation at a specified pressure ramp to achieve separation of higher boiling components)
- **Manual process control**
(active control of the distillation via the setpoint pressure)

To change to a different operating mode, the process is stopped and then restarted in the new mode.

6. Setup and connection

- ➔ Connect the vacuum controller only under the operating parameters and conditions described in Chapter 4. Technical data (page 8).
- ➔ Observe the safety precautions (see Chapter 3, page 7).

6.1. Set up or install

- ➔ Before installation, allow the vacuum controller to get to ambient temperature at the installation location.
- Installation location
- ➔ Make sure that the installation location is dry and the vacuum controller is protected against water in the form of rain, spray, splashes and drips.
- Cooling air supply
- ➔ When installing the vacuum controller, ensure that maximum permissible media and ambient temperatures (Tab. 2, p. 8) are not exceeded.
Make sure there is an adequate flow of fresh air.
 - ➔ Choose a safe location (flat surface) for the vacuum controller.
 - ➔ Protect the vacuum controller from dust.
 - ➔ Protect the vacuum controller from vibration and impact.

In principle, there are three different options for setting up and installing the vacuum controller:

- Bench version 1 (see Fig. 2, left)
- Bench version 2 (see Fig. 2, center)
- Installation version (see Fig. 2, right)

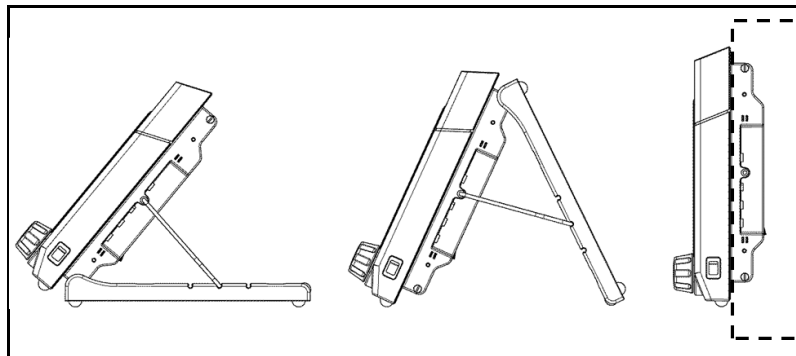

Fig. 2: Set-up/installation options for the vacuum controller

Bench versions 1 and 2 (see Fig. 2 left and center)

The angle of the vacuum controller can be adjusted by the positions of the foot and the wire support (mounting options, see Fig. 1/2).

Installation version (see Fig. 2, right)

Requirements

- Foot and wire support dismantled
 - Cut-out available in the housing (see Tab. 3 and Fig. 3)
1. Place the vacuum controller in cut-out of the housing.
 2. Fix the vacuum controller in place from behind with four screws (accessories).

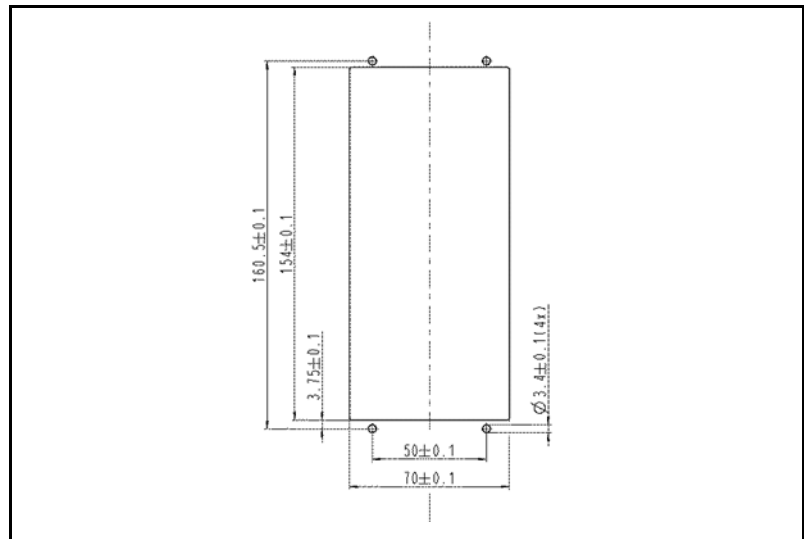

Fig. 3: Dimensions for installing the vacuum controller

- i** Remember that in the installation version, the outputs of the control unit and the network connection can be accessed only from inside the housing.
- i** KNF recommends a maximum wall thickness of 4 mm. If you need a bigger wall thickness, please contact the KNF customer service.

6.2. Connections

Connected components

➔ Only connect components to the vacuum controller that are designed for the vacuum controller's pneumatic data (see Chapter 4, page 8).

1. Connect the vacuum chamber and the vacuum source to the hose connectors of the control unit (Fig. 1/13 and 15, p. 12).



Use vacuum hoses for this.

2. If necessary:
Connect the inert gas feed to the ventilation connection (Fig. 1/14, p. 12). Observe the corresponding safety precautions in Chapter 3.
3. Connect the cable for the pressure sensor (Fig. 1/17, p. 12) to the 3-pole socket on the back of the vacuum controller (Fig. 1/9, p. 12).
4. Connect the cable for the valves (Fig. 1/16, p. 12) to one of the two 4-pole sockets on the back of the vacuum controller (Fig. 1/11, p. 12).



The vacuum controller automatically recognizes which of the two 4-pole sockets the cable is connected to. If necessary, the second, free socket can be used, for example, to activate a coolant valve.

5. If necessary, connect the interface cable (accessories) to the variable KNF pump and the vacuum controller VC 900 (Fig. 1/10).
6. Connect the power supply to the vacuum controller (Fig. 1/12, p. 12) and plug it into a properly installed safety socket.

7. Operation

7.1. Initial start-up

You need a vacuum source to operate the vacuum controller. If you do not have one, the vacuum controller can be used only to measure vacuum.

Before switching on the vacuum controller, check the following points:

Prerequisites for start-up
<ul style="list-style-type: none"> ▪ All hoses attached properly ▪ Specifications of the power supply correspond with the data on the vacuum controller's type plate ▪ Vacuum controller at ambient temperature ▪ If the vacuum controller is ventilated through the inert gas connection (Fig. 1/14, p. 12) no reactive, explosive, or otherwise dangerous mixtures can form (use inert gas if necessary)

Tab. 5

- Operate the vacuum controller only with the operating parameters and conditions described in Chapter 4, Technical data (page 8).
- Make sure the vacuum controller is used properly (see Chapter 2.1, page 5).
- Exclude the possibility of the vacuum controller being used improperly (see Chapter 2.2, page 6).
- Observe the safety precautions (see Chapter 3, page 7).



WARNING

Personal injury caused by poisoning or explosion. and damage to the vacuum controller

- Make sure that no reactive or explosive mixtures will be produced when ventilating the vacuum controller through the air inlet.



WARNING

Excessive pressure may cause the control unit to rupture

- Do not exceed the maximum permissible operating pressure (0 bar).
- Monitor pressure during operation.
- If pressure exceeds the maximum permissible operating pressure of the vacuum controller: Immediately switch the vacuum controller off and fix the fault (see Chapter 9, page 25).

Switch on the vacuum controller

→ Switch on the vacuum controller at its I/O switch (see Fig. 1/3, page 12).

i Refer to Chapter 8, page 19 for information on operating the vacuum controller.

7.2. Stopping operation

→ Stop the ongoing process.

→ Before switching off the control unit, flush it with air (or with inert gas if required for safety reasons) under atmospheric conditions (ambient pressure) for about five minutes.

→ Switch off the vacuum controller at its I/O switch (see Fig. 1/3, page 12).

8. Operating the vacuum controller

8.1. Vacuum controller

8.1.1. General functions and displays

The vacuum controller is operated with the aid of

- a rotary/push knob (Fig. 1/4) and
- a touchscreen (Fig. 1/1).

The **rotary/push knob** has the following functions:

- Rotate the knob: Changes pump capacity or the selected pressure setting (depending on selected operating mode).
- Press the knob: Interrupts the active process and switches to manual process control (pressing causes evacuation).

Touchscreen contents:

- Display of the most important process variables (Fig. 4, page 19);
- Menus for selecting the operating mode and units for pressure display (Fig. 5, page 20);
- Operating keys (Fig. 5, page 20) with the functions:
 - Start and stop the process;
 - Open and close the ventilation valve;
 - Opening and closing coolant valve (accessory).

Displays

- 1 Process time
- 2 Actual pressure in selected pressure unit
- 3 Process active
- 4 Depends on operating mode:
Capacity as a percentage or setpoint pressure in the selected pressure unit (if in *Evacuate* or *Automatic* operating mode no pump is connected to the vacuum controller, the following symbol is displayed



- 5 Explanation of the rotary/push knob functions (Rotate: change capacity; push: interrupt operating mode and switch to manual process control)

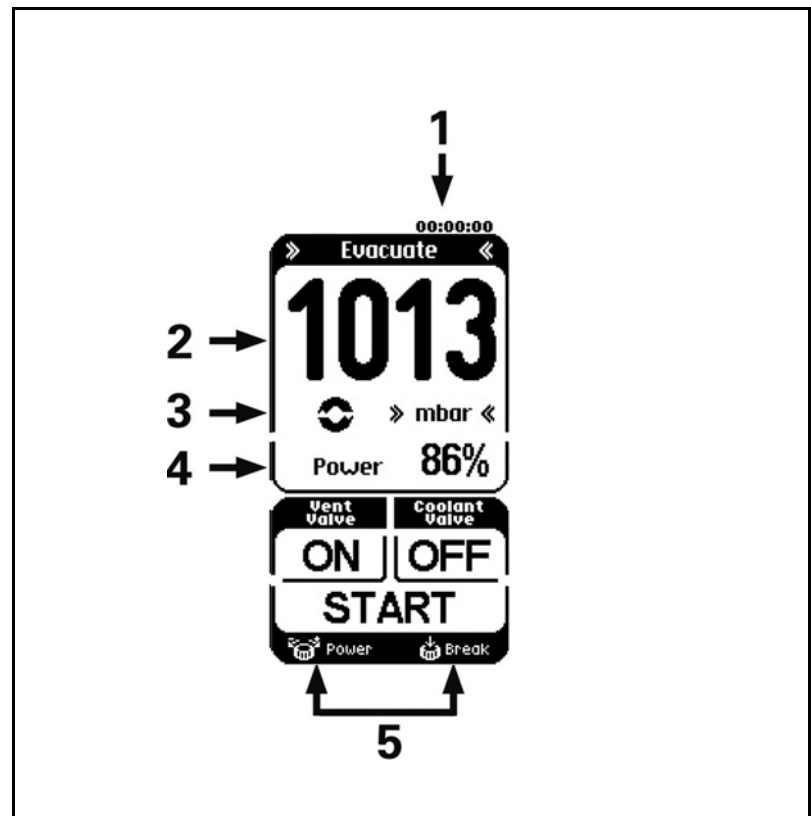

Fig. 4: Displays on the touchscreen

Menus and buttons

- 1 Operating mode menu
- 2 Pressure unit menu
- 3 Button for ventilation valve:
ON = open
- 4 Button for coolant valve
(accessory):
ON = open
- 5 Button for the process:
START = start
STOP = stop

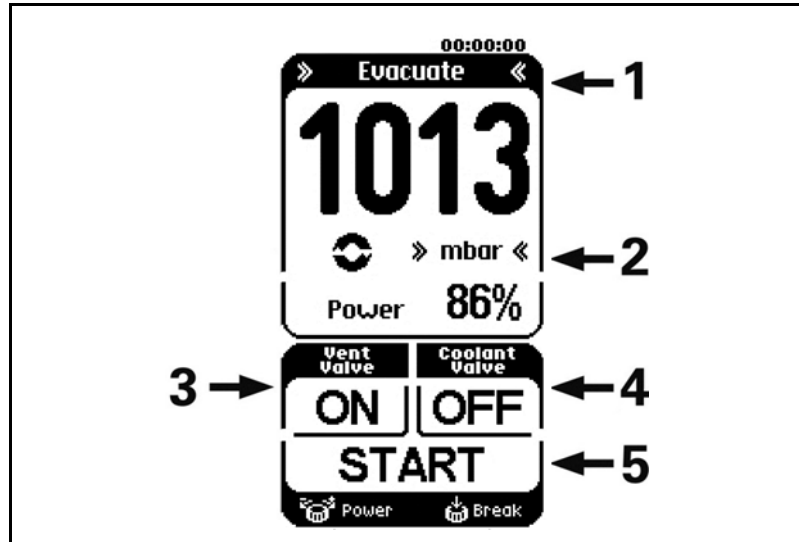

Fig. 5: Menus and buttons on touchscreen

8.1.2. Operation

Menu language

When the vacuum controller is switched on, on the start page you can choose between German, English, French, Italian, Spanish, Dutch, Japanese, and Chinese. The selection can be made only immediately after switching on.

Pressure unit

Process pressure can be displayed in mbar, bar, hPa, or Torr.

Use the pressure unit menu to select the pressure unit (button on touchscreen; see Fig. 6).

- i** Pressure units can be changed only when no process is active.
- i** To change the pressure unit, you have to change to a different operating mode temporarily.



Fig. 6: Pressure units menu

Operating modes

The current operating mode is displayed at the top of the touchscreen. Press on this line of the touchscreen to open the menu for changing operating mode (see Fig. 7, top image).

i Operating mode can be changed only when no process is active.

Switching to manual process control (break)

- Press briefly on the rotary/push knob:
Manual process control; actual pressure will be adopted as the setpoint pressure and be actively adjusted.

Within manual process control

- Press the rotary/push knob:
Vacuum controller opens vacuum valve and vacuum chamber is evacuated.
- Let go:
Actual pressure will be adopted as setpoint pressure.
- Rotate the knob:
Changes setpoint pressure.

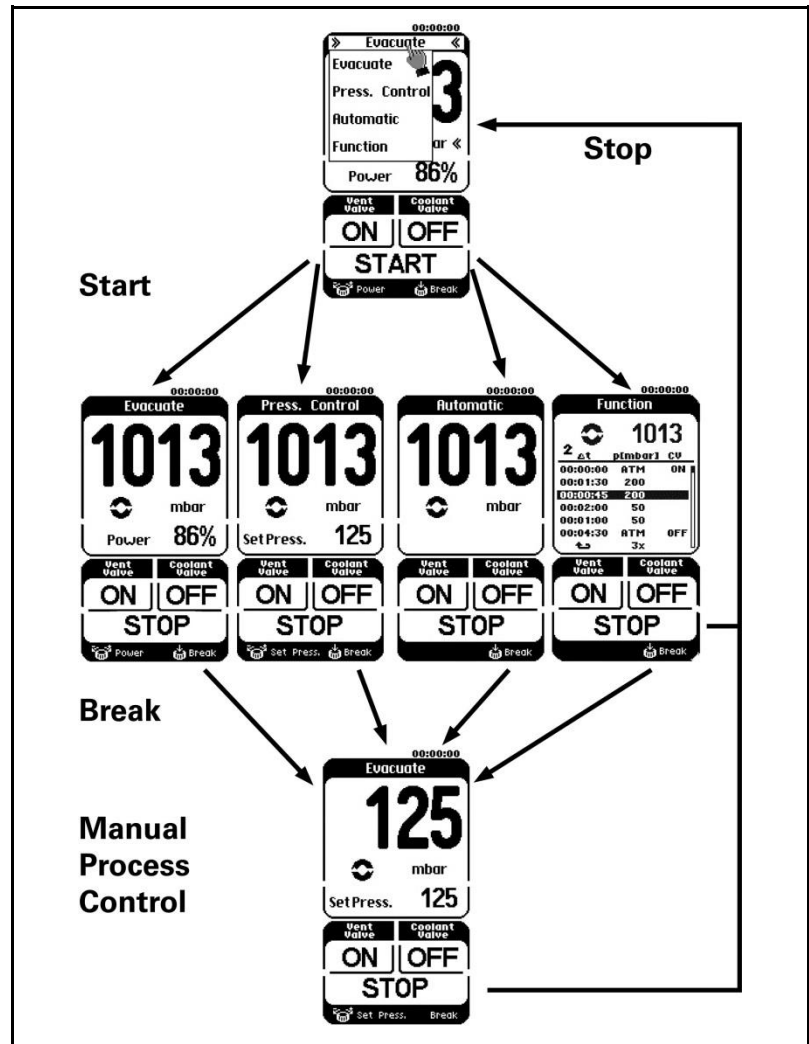

Fig. 7: Operating mode menu

Starting and stopping the process

Pressing the *START* button starts a process.

Pressing the *STOP* button stops a process.

Open and close the ventilation valve**WARNING**

Personal injury caused by poisoning or explosion and damage to the control unit

→ Make sure that no reactive or explosive mixtures will be produced when ventilating the control unit through the air inlet.

Press and hold the *ON* button (Fig. 5/3, p. 20) to open the ventilation valve.

i Press the *ON* button for longer than 3 seconds to open the ventilation valve permanently. The display on the screen changes to *OFF*.

If the ventilation valve is permanently open, you can press *OFF* to close it again.

Opening and closing coolant valve (accessory)

Press the *ON* button (Fig. 5/4, p. 20) to open the coolant valve.

Press the *OFF* button (Fig. 5/4, p. 20) to close the coolant valve again.

Entering values in Evacuate operating mode (only if a variable KNF pump is connected to the vacuum controller)

Use the rotary/push knob to set pump capacity.

Entering values in Pressure Control operating mode

Use rotary/push knob to set desired pressure.

Entering values in Automatic operating mode

Not necessary to enter value.

Entering values in Function operating mode

The desired pressure curve is entered via data points that connect the vacuum controller to pressure ramps.

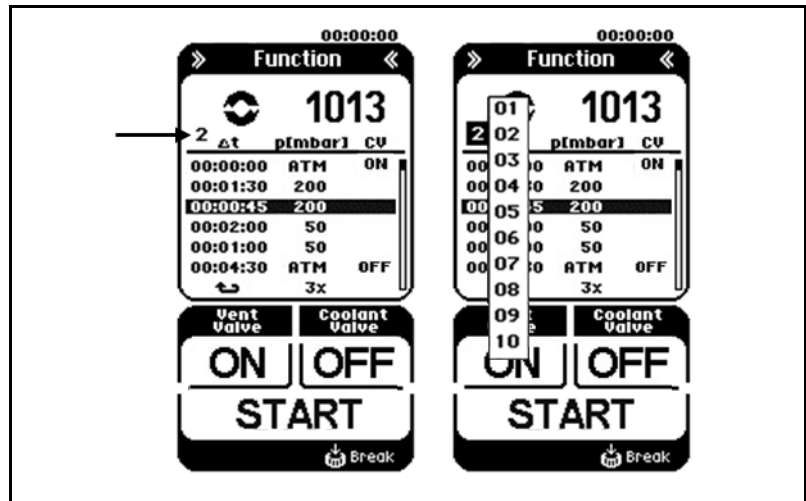

Fig. 8: Menu in Function operating mode

Entering the data points (up to 12):

1. Length of time from previous data point: Δt
2. Setpoint pressure: p (mbar) / p (bar) / p (hPa) / p (Torr)
3. Command for coolant valve (accessory):
CV ON: Open valve; CV OFF: Close valve

Line selection (see Fig. 8):

- To change the line:
Turn the rotary/push knob.
- Select lines to edit:
Press the rotary/push knob.

Editing a selected line

- To change columns
(e.g. from Δt to p (mbar)):
Press the rotary/push knob.
- To change an entry:
Turn the rotary/push knob.

i After the last column (CV), the display automatically returns to line selection and jumps to the next line.

i If you are in edit mode and have not entered any data within 3 seconds, the display automatically returns to line selection.

i The function values of the data point table are stored in an internal memory of the vacuum pump system when the process is started and are available the next time you start the system.

i Changes to the function values (data point table) are applied directly by the PC software if you are using it at the same time.

Repeating/deleting data points:

In the column for the time intervals, the following symbols can be inserted beneath the value 00:00:00:

-  = repeat. The number of required repeats can now be entered in the setpoint pressure field.
- ... = delete the data point.

In both cases, all following data points are automatically deleted.

Calling the stored data point tables:

- Press the button to select data point tables (arrow in Fig. 8) and select the required data point table.
You can now see the data point table that is stored under the number.

i Up to 10 different data point tables can be stored and called as required. The number in the display (arrow in Fig. 8) indicates the data point table that is currently selected.

8.2. Software

i Please see the delivered CD for information on operating the vacuum controller via software.

9. Troubleshooting



Risk of electric shock, danger of death

→ Separate the vacuum controller from the power supply before working on the vacuum controller.

DANGER → Make sure that vacuum controller is de-energized.

- Vacuum controller generally: see Tab. 6.
- Software operation: see Tab. 7.

Vacuum controller generally		
Error	Possible cause	Remedy
The vacuum controller is switched on, but the display does not illuminate.	Power cable not plugged in.	→ Connect the vacuum controller with a properly installed grounded socket via the power supply unit.
	No voltage in the mains.	→ Check the room's fuses.
Vacuum controller's display stays dark.	Vacuum controller is not switched on.	→ Switch on the vacuum controller.
Pressure display shows implausible values.	Pressure units were changed.	→ Select the desired pressure unit.
	Leak in the system.	→ Repair the leak.
	Pressure sensor has to be recalibrated.	→ Contact KNF Service.
Insufficient vacuum generated although the vacuum source is connected.	Vacuum chamber leaking.	1. Check by closing the gas inlet (Fig. 1/ 19, p. 12). If the vacuum controller shows sufficient vacuum, the vacuum chamber has a leak. 2. Repair the leak in the vacuum chamber.
	Hose connection leaking.	→ Make sure the hoses are properly seated on the hose connectors. → Replace leaking hoses. → Replace leaking hose connectors. → For the order number, refer to Chapter 10, page 28.

Tab. 6 (part 1)

	<p>Ventilation valve leaking.</p>	<p>➔ Temporarily close the ventilation connection (Fig. 1/14, p. 12). If there is no leak when the ventilation connection is closed, the ventilation valve has a leak. In this case:</p> <p>➔ Rinse the ventilation valve:</p> <ol style="list-style-type: none"> 1. Close the gas inlet (Fig. 1/19). 2. If necessary for safety reasons: Connect inert gas to the ventilation connection. The safety precautions in Chapter 3 must be observed at all times. 3. Run the vacuum controller in <i>Evacuate</i> operating mode (if a variable KNF pump is connected: at full pump speed). 4. Open the gas inlet again. <p>➔ If the problem remains, contact KNF Service.</p>
	<p>Condensate in the control unit.</p>	<p>➔ Dry the system with fresh air or, if necessary for safety reasons, with an inert gas:</p> <ol style="list-style-type: none"> 5. If inert gas is used: Connect the inert gas source to the gas inlet (Fig. 1/14, p. 12) and run the vacuum controller in <i>Evacuate</i> operating mode (if a variable KNF pump is connected: at full pump speed). The safety precautions in Chapter 3 must be observed at all times. 6. If air is used: Open the gas inlet (Fig. 1/13, p. 12) to the environment and run the vacuum controller in <i>Evacuate</i> operating mode (if a variable KNF pump is connected: at full pump speed). 7. After 30 seconds, close the gas inlet and run the vacuum controller for 30 seconds in vacuum. 8. Repeat 3-5 times. <p>➔ If the problem occurs frequently: Place the control unit higher than the vacuum chamber.</p>

Tab. 6 (part 2)

Software operation		
Error	Possible cause	Remedy
The PC software cannot establish a connection with the vacuum controller.	Vacuum controller is not switched on.	→ Switch on the vacuum controller.
	The USB connection between the vacuum controller and the PC is not working.	→ Check that the USB cable is properly connected. If necessary, disconnect the USB cable and reconnect it (re-set the USB interface).
Pressure display shows implausible values.	Pressure units were changed.	→ Select the desired pressure unit.
	Leak in the system.	→ Repair the leak.
	Pressure sensor has to be recalibrated.	→ Contact KNF Service.

Tab. 7

Fault persists

If you are still unable to diagnose the problem, please send the vacuum controller to KNF customer service (see address on last page).

1. Rinse the control unit with air under atmospheric conditions (ambient pressure) for about 5 minutes (if necessary for safety reasons: with an inert gas) to purge dangerous or aggressive gases from the control unit and tubing.
2. If possible, wipe the vacuum controller with a dry cloth. Solvent should be used for cleaning only if the materials are not corroded (ensure compatibility of the material). If compressed air is available, blow out the parts.
3. Send the vacuum controller, with completed Health and safety clearance and decontamination form (see Chapter 12), to KNF stating the nature of the transferred medium.

10. Spare parts and accessories

10.1. Spare parts

Spare part	Order No.
Power supply for vacuum controller	302033
Mini USB cable	136174

Tab. 8

10.2. Accessories

Accessories	Order No.
Coolant valve	305721
Chemical-resistant protective membrane for the vacuum controller display.	117407
Screws for installation version	305722
Interface cable Vacuum controller – KNF pump (2m)	307757
Interface cable Vacuum controller – KNF pump (5m)	307758

Tab. 9

11. Returns

Pumps, vacuum controller and systems used in laboratories and process-based industries are exposed to a wide variety of conditions. This means that the components contacting pumped media could become contaminated by toxic, radioactive, or otherwise hazardous substances.

For this reason, customers who send any pumps, vacuum controller or systems back to KNF must submit a Health and safety clearance and decontamination form in order to avoid a hazardous situation for KNF employees. This Health and safety clearance and decontamination form provides the following information, among other things:

- physiological safety
- whether medium-contacting parts have been cleaned
- whether the equipment has been decontaminated
- media that have been pumped or used

To ensure worker safety, work may not be started on pumps, vacuum controller or systems without a signed Health and safety clearance and decontamination form.

For optimal processing of a return, a copy of this declaration should be sent in advance via e-mail, regular mail, or fax to KNF Customer Service (refer to final page for address). In order to avoid endangering employees who open the shipment's packaging, despite any residual hazards, the original version of the Health and safety clearance and decontamination form must accompany the delivery receipt on the outside of the packing.

The template for the Health and safety clearance and decontamination form is included with these Operating Instructions and may also be downloaded from the KNF website.

The customer must specify the device type(s) and serial number(s) in the Health and safety clearance and decontamination form in order to provide for the unambiguous assignment of the Declaration to the device that is sent to KNF.

In addition to the customer's declaration of physiological safety, information about operating conditions and the customer's application are also of importance to ensure that the return shipment is handled appropriately. Therefore, the Health and safety clearance and decontamination form requests this information as well.

12. Health and safety clearance and decontamination form



Form: Rev. 02 / download: www.knf.com

Health and safety clearance and decontamination form

This declaration must be present and complete (the original must accompany the shipment's delivery receipt) before the returned device can be examined.

Device type:
Serial number(s):
.....
.....

Reason for returning the device (please describe in detail):

(The device(s) was(were) in operation yes no)
.....
.....
.....
.....
.....

We confirm that the above device(s)

has(have) pumped exclusively **physiologically unobjectionable** media and that it(they) are free of hazardous materials and any materials that are harmful to health.

Pumped media:
The device(s) was(were) cleaned yes no

has(have) pumped media of the following category(categories) which are not physiologically unobjectionable and that cleaning of the device(s) (potentially only media-contacting parts) is required.

Name, chemical formula, Material Safety Data Sheet

- aggressive
- biological
- radioactive
- toxic
- other

The device(s) was(were) decontaminated and work can proceed without special measures yes

Method / proof:
.....

The device(s) was(were) not decontaminated and special measures are required before starting work yes

Measures:
.....

Legally binding declaration

We herewith affirm that the information provided in this form is correct and complete. Shipment of the devices and components is in compliance with statutory regulations.

.....
Company (stamp) Date Name Authorized signature Position

KNF worldwide

Find your local KNF partner at: www.knf.com